

# ezSystem elab16m Project 4s: Washing Machine control

## Project Description:

The project is a washing machine cycle controller that uses the elab16m, a yellow LED (on board), a red LED, an electric motors and a buzzer.

The washing machine controller will start a wash cycle by pumping water into the washing machine, indicated by a yellow LED. The motor will then turn in one direction and pause, turn in the opposite direction, pause and repeat five times to “wash” the clothes. After that the water will be pumped, indicated by a red LED.

## 1. Design the Washing Machine Control

Use ezCircuit Designer to construct an input/output (I/O) diagram

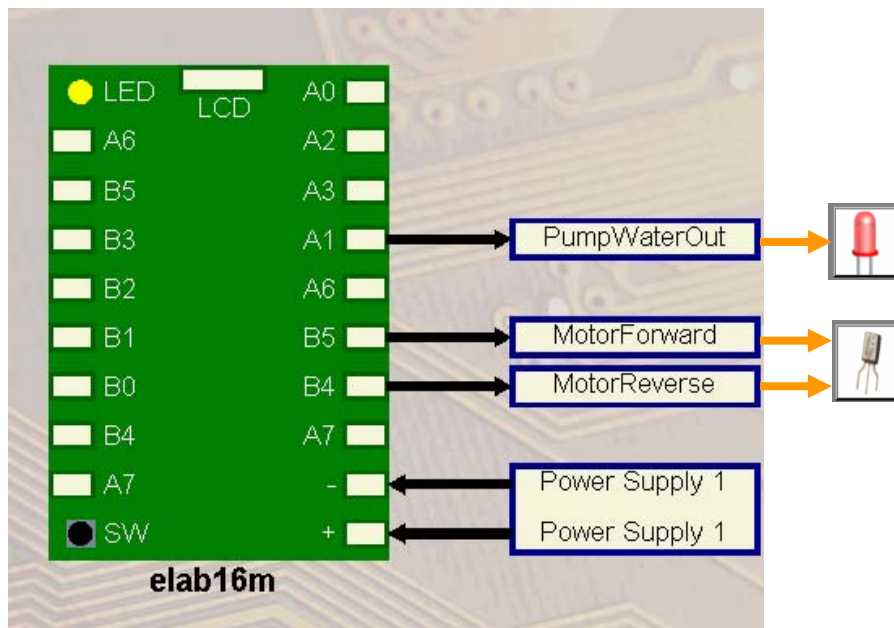

## 2. Build the Washing Machine Control

Use ezCircuit Designer I/O diagram to connect the hardware.

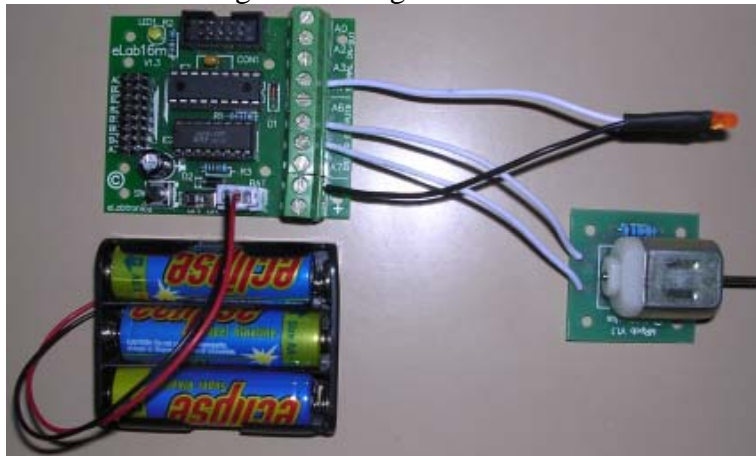

### 3. Program the Washing Machine Control

Use ezCoreChart to program the functions of the washing machine

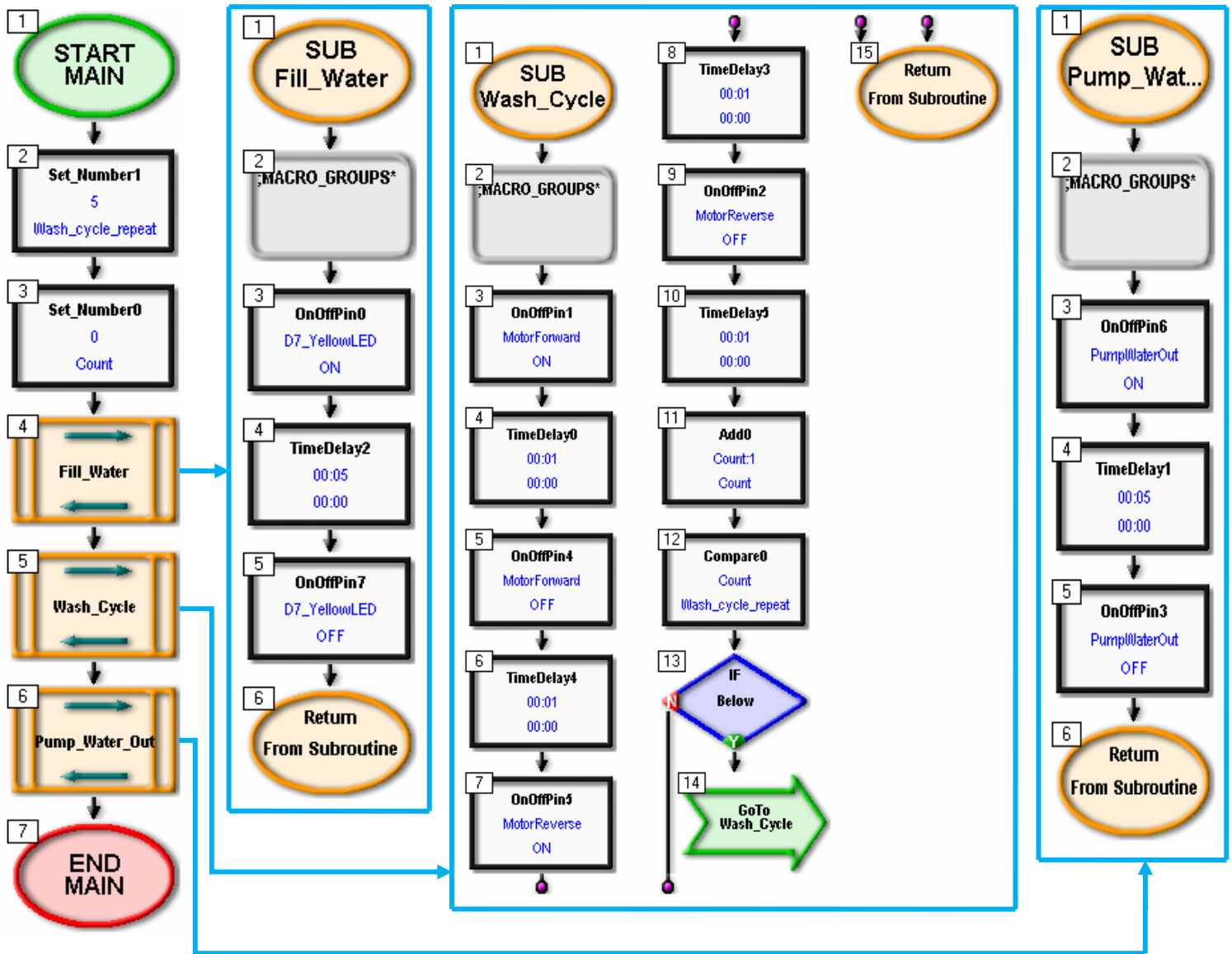

#### Extension:

Devise a solution to the extension problem. Make small changes to the program and test the program regularly.

1. Add a spin cycle to the program. Start the motor for fifteen seconds to remove excess water from the clothes.

**Suggestion:** If an eLabtronics MDriver board is available, the buzzer in the project can be replaced with a motor to operate the washing machine.

2. Replace the buzzer used in this project with an MDriver board and a motor.