

# ezSystem elab16m Project 2s: Smart Street Light

## Project description:

The project is a smart street light that uses the elab16m, a Light Dependent Resistor and a LED as the smart street light.

The LED will turn on when the light level is low and turn off when the light level is high.

## 1. Design the Smart Street Light

Use ezCircuit Designer to construct an input/output (I/O) diagram

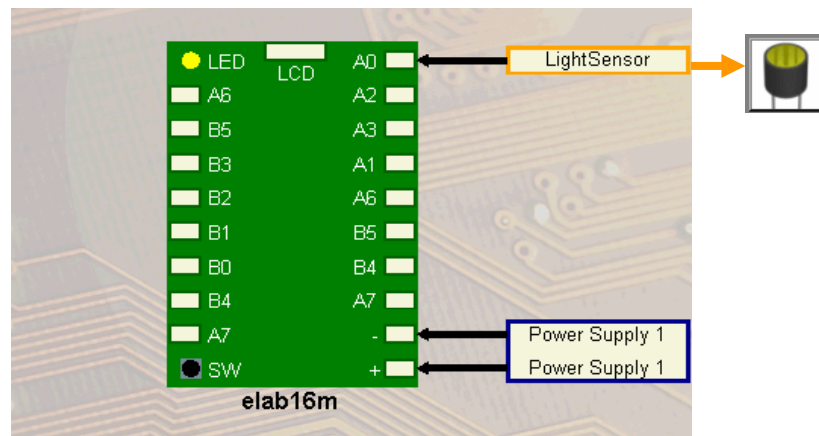

## 2. Build the Smart Street Light

Use ezCircuit Designer I/O diagram to connect the hardware

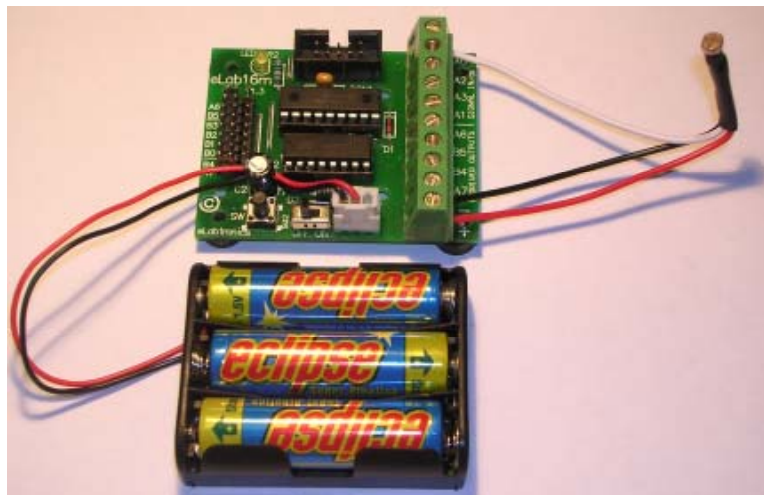

### 3. Program the Smart Street Light

Use ezCoreChart to program the functions of the smart street light

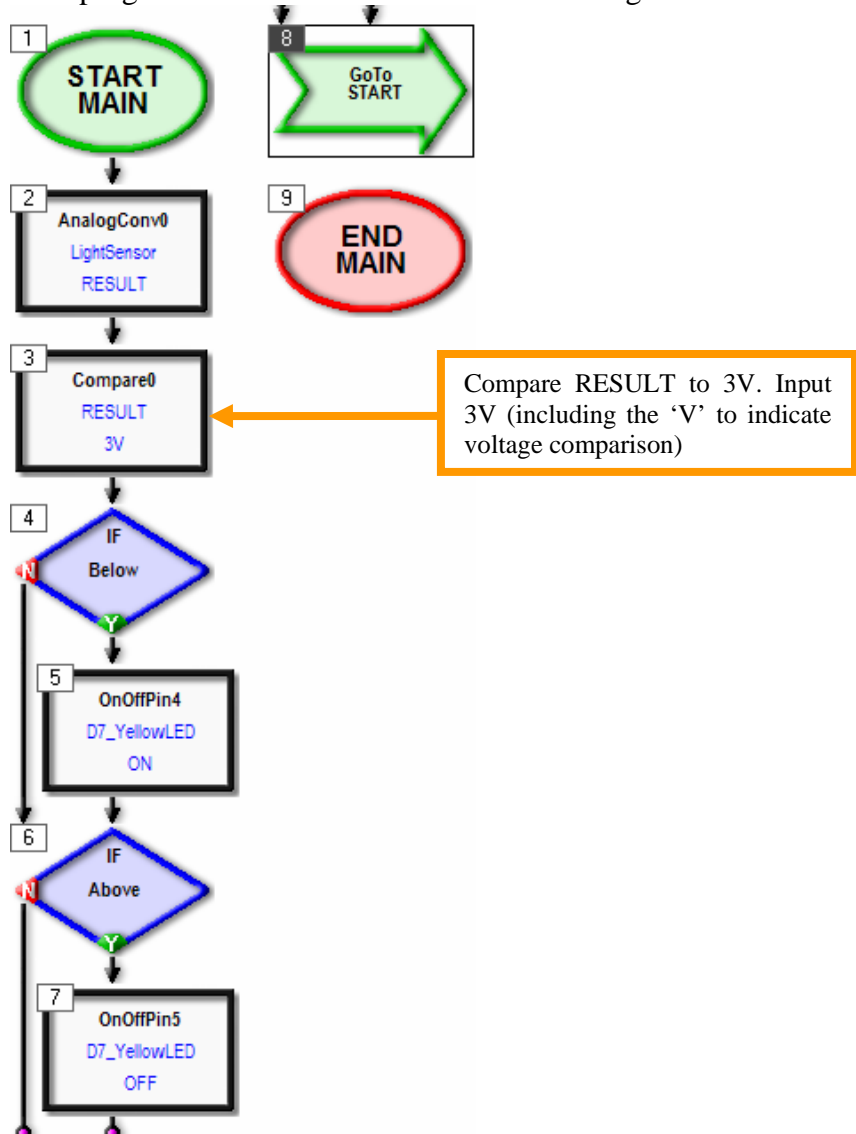

#### Extension:

Work through the following challenge and see if you can devise a solution to the problem. Make small changes to the program and test run the program regularly.

What will happen if the head lights of a car were to shine on the street light sensor at night? The program will turn the off the street light thinking that it is day light.

1. Modify the smart street light program so that about five seconds of light on the light sensor is required to make the street light switch off.

**Hint:** Since the car head light is a spurious and momentary signal and will not expose the light sensor for a long period of time, a time delay can be used. Where can the time delay be inserted in the program?